

# Technical Bulletin

## 'G' Series - Features

### General

The 'G' Series diaphragm has been developed from Introl's highly successful 'A' Series range. The use of an involute rolling diaphragm permits the long travels required without the need for expensive hardware normally associated with rolling diaphragm types. A wide selection of spring ranges are available and the use of ball thrust races prevents torsional loads being applied to the diaphragm as well as reducing the effort required to precompress the spring. The modular design allows retrofitting of many of the optional extras without modification of the basic unit. For standard applications the diaphragm actuator offers the following advantages over the conventional piston type:-

- Simple cost effective design.
- Increased life and reliability, accurate honed bores with delicate sealing systems are not required.
- Low cost, simple maintenance.
- High performance, low friction rolling diaphragm gives comparable hysteresis with piston types.

### Performance:

- Reliability.
- High Power.
- Full response.
- Low Hysteresis.

### Design Flexibility:

- Reversible fail action without extra parts.
- Split Coupling for easy attachment to valve plug stem.
- Wide selection of optional accessories available, many without modification of standard unit.
- Involute rolling diaphragm simplifies actuator design.
- Variable stroke up to 8".

### Design Integrity:

- Robust steel construction.
- Low stressed alloy steel springs.
- Twin seal seal box with wiper system.

### Quality Manufacturing:

- High quality material with traceability throughout manufacture.
- Quality Assurance systems in accordance with BS/EN ISO 9001.
- Comprehensively tested to ensure specified performance on site.

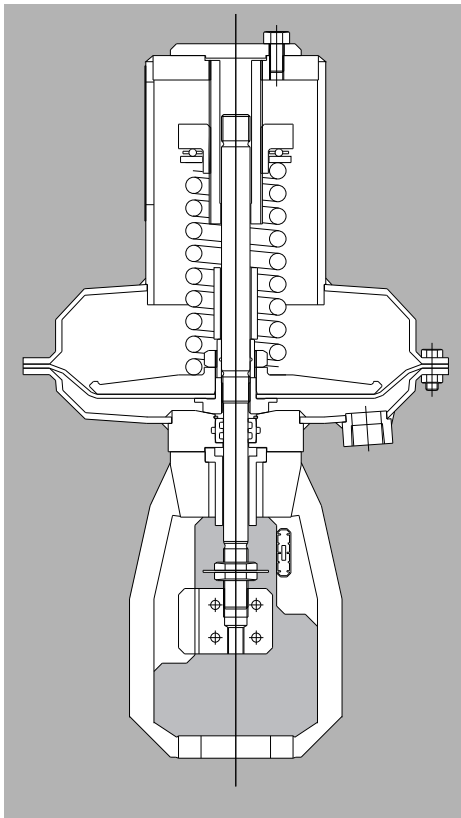

Figure 1. Cross Sectional Drawing 'G' Series Diaphragm Actuator (Reverse Acting).

Table 1. Standard Materials of construction.

Part Description	Material
Yoke	S.G. Iron
Diaphragm Case	Steel
Spring Tube Assembly	Steel
Diaphragm	Nitrile Rubber
Seals	Nitrile Rubber
Spring	Cr/V Alloy Steel
Case Screws	H.T. Steel

Alternative material combinations suitable for offshore and extremely corrosive duties are available. Consult factory for details.

Table 2. Actuator Working Conditions.

Actuator Ref.	Max. Working Pressure		Min. Working Temp		Min. Storage Temp		Max. Working Temp	
	psig	barg	°C	°F	°C	°F	°C	°F
075	60	4.1	-40	-40	-55	-67	90	194
150								
300	50	3.4	-40	-40	-55	-67	90	194

Standard actuators are suitable of air operation. For other operating mediums eg. natural gas, please consult factory.

Actuators for low temperature applications are available on request.

## Guide to Accessory Options

### Top Mounted Handwheel/Jacking Screw (Fig. 2)

The top mounted handwheel is of the continuously connected design. It is available for the 075 and 150 size actuators and may be fitted retrospectively without any modification of the standard unit. The handwheel is capable of providing operating forces in either direction and does not rely on the actuator spring to provide return motion. The handwheel can also act as a limit stop to limit either the amount of valve opening or closing.

### Side Mounted Handwheel unit (Continuously Connected) (Fig. 3)

This unit is available for all sizes of actuator with travels up to and including 8". The arrangement operates through a permanently lubricated worm gear box which is conveniently located between the yoke and actuator to give a readily accessible handwheel position. The gearing has been selected to ensure easy operation even with the maximum actuator power. The side mounted handwheel unit may be fitted retrospectively if required.

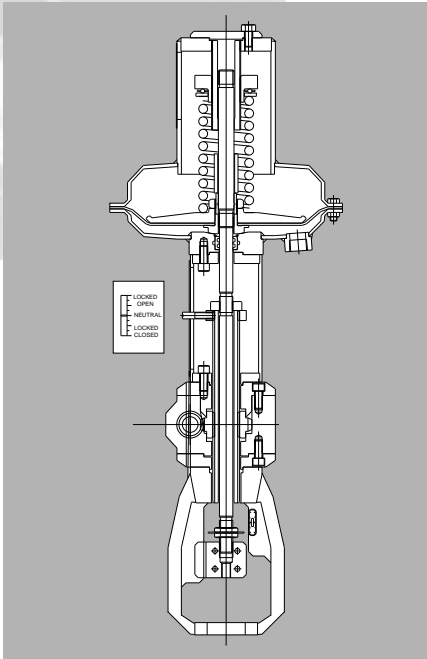

Figure 3. Side Mounted Handwheel Unit (Continuously connected).

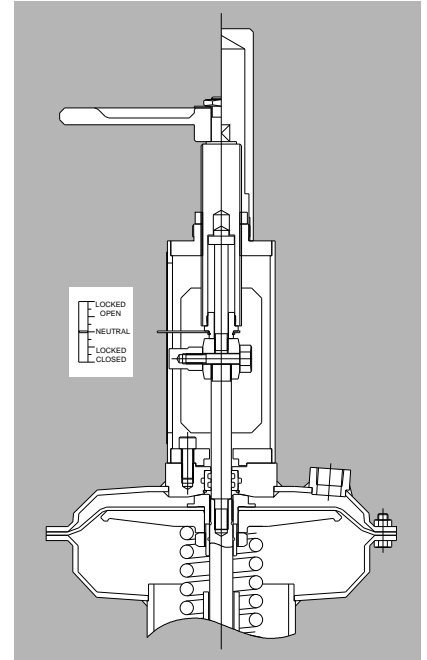

Figure 2. Top Mounted Handwheel.

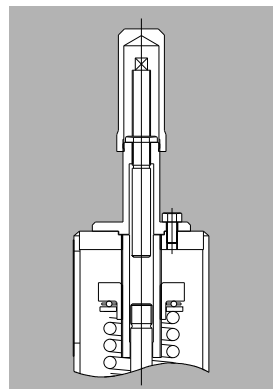

Figure 4. Maximum Limit Stop.

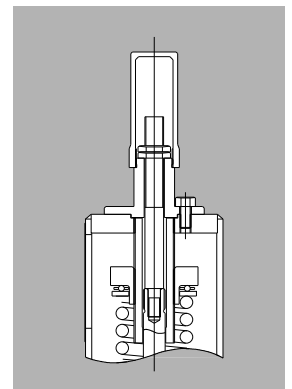

Figure 5. Minimum Limit Stop.

Table 3. Handwheel Specification.

Actuator Reference	Top Mounted Handwheel					Side Mounted Handwheel			
	Handwheel Dia. ins. (mm)	Turns/inch Travel	Turning Force		Stem Force lbf (kgf)	Handwheel Dia. ins. (mm)	Turns/inch Travel	Turning Force lbf (kgf)	Stem Force lbf (kgf)
			Assisting lbf (kgf)	Resisting lbf (kgf)					
075	12 (305)	6	25 (11)	51 (23)	3375 (1531)	12 (305)	30	23 (10)	3375 (1531)
150	12 (305)	6	96 (44)	157 (71)	6750 (3063)	12 (305)	30	45 (20)	6750 (3063)
300	N/A	N/A	N/A	N/A	N/A	12 (305)	48	46 (21)	10500 (4764)

Table 4. Air Capacities.

Actuator Reference	Travel		Volume					
			Zero Travel		Swept		Full Travel	
	ins.	mm	in <sup>3</sup>	cm <sup>3</sup>	in <sup>3</sup>	cm <sup>3</sup>	in <sup>3</sup>	cm <sup>3</sup>
075	1 1/8	28	31	508	85	1393	116	1901
	1 1/2	38			114	1868	145	2376
	2 1/4	57			170	2786	201	3294
150	1 1/8	28	123	2016	167	2737	290	4753
	1 1/2	38			222	3638	345	5654
	2 1/4	57			333	5457	456	7473
	3 1/2	89			518	8488	641	10504
	4	102			592	9701	715	11717
	5	127			740	12126	863	14142
300	1 1/8	28	268	4392	351	5752	619	10144
	1 1/2	38			468	7669	736	12061
	2 1/4	57			702	11504	970	15896
	3 1/2	89			1092	17895	1360	22287
	4	102			1248	20451	1516	24843
	5	127			1560	25564	1828	29956
	6	152			1872	30677	2140	35069
	7	178			2184	35789	2452	40181
	8	203			2496	40902	2764	45294

Table 5. Actuator Powers.

Actuator Size	Max. Travel		Max. Op. Pressure		Spring Range		Gross Thrust		Nett Thrust		Spring Extended	
	ins.	mm	psig	bar g	psig	bar g	lbf	kgf	lbf	kgf	lbf	kgf
075	2.25	57	60	4.1	3-15	0.2-1.0	4500	2042	a3375	1531	225	102
					6-18	0.4-1.2			3150	1429	450	204
					6-30	0.4-2.0			2250	1021	450	204
					8-32	0.55-2.2			2100	953	600	272
					11-22	0.75-1.55			2850	1295	825	375
					14-30	1.0-2.0			2250	1022	1050	476
					14-33	1.0-2.3			2025	920	1050	476
150	5.00	127	60	4.1	3-15	0.2-1.0	9000	4083	6750	3063	450	204
					6-18	0.4-1.2			6300	2858	900	408
					6-30	0.4-2.0			4500	2042	900	408
					8-32	0.55-2.2			4200	1906	1200	544
					11-21	0.75-1.45			5850	2659	1650	749
					11-28	0.75-1.95			4800	2181	1650	749
					12-21	0.85-1.45			5850	2659	1800	818
					12-28	0.75-1.95			4800	2181	1800	818
					15-31	1.0-2.2			4350	1977	2250	1021
15-33	1.0-2.3	4050	1840	2250	1021							
300	8.00	203	50	3.4	3-15	0.2-1.0	15000	6806	10500	4764	900	408
					6-18	0.4-1.2			9600	4356	1800	817
					6-30	0.4-2.0			6000	2722	1800	817
					8-32	0.55-2.2			5400	2450	2400	1089
					10-19	0.7-1.3			9300	4227	3000	1363
					10-29	0.7-2.0			6300	2863	3000	1363
					11-21	0.75-1.45			8700	3954	3300	1497
					12-29	0.85-2.0			6300	2863	3600	1633
					14-32	1.0-2.2			5400	2450	4200	1906
					14-33	1.0-2.3			5100	2318	4200	1906
					15-32	1.0-2.2			5400	2450	4500	2042
					15-33	1.0-2.3			5100	2318	4500	2042
					16-33	1.1-2.3			5100	2318	4800	2178
20-40	1.4-2.8	3000	1363	6000	2727							

Table 6. Standard Available Spring Ranges.

Actuator Size	Background colour	Travel Range				Spring No.	No. of Stripes	Colour	
		in	mm	psig	bar g				
075	Green	1.125	28	3-15 (6-18)	0.2-1.0 (0.4-1.2)	1	NONE	NONE	
				6-30 (8-32)	0.4-2.0 (0.55-2.2)	2	ONE	BLACK	
				11-22	0.75-1.55	32	ONE	RED	
				14-33	1.0-2.8	33	TWO	BLUE	
	Purple	2.25	57	38	3-15 (6-18)	0.2-1.0 (0.4-1.2)	32	ONE	RED
					6-30 (8-32)	0.4-2.0 (0.55-2.2)	33	TWO	BLUE
					14-30	1.0-2.0	42	TWO	GREY
					3-15 (6-18)	0.2-1.0 (0.4-1.2)	41	ONE	GREY
150	Yellow	1.125	28	6-30 (8-32)	0.4-2.0 (0.55-2.2)	4	ONE	WHITE	
				6-30 (8-32)	0.4-2.0 (0.55-2.2)	5	TWO	WHITE	
				11-21	0.75-1.45	7	NONE	NONE	
				14-33	1.0-2.3	8	ONE	BLACK	
				3-15 (6-18)	0.2-1.0 (0.4-1.2)	7	NONE	NONE	
				6-30 (8-32)	0.4-2.0 (0.55-2.2)	8	ONE	BLACK	
	Yellow	1.50	38	57	12-21	0.85-1.45	10	ONE	RED
					15-33	1.0-2.3	11	ONE	BLUE
					3-15 (6-18)	0.2-1.0 (0.4-1.2)	10	ONE	RED
					6-30 (8-32)	0.4-2.0 (0.55-2.2)	11	ONE	BLUE
					15-31	1.0-2.2	44	TWO	RED
					3-15 (6-18)	0.2-1.0 (0.4-1.2)	43	ONE	RED
	Grey	3.50	89	102	6-30 (8-32)	0.4-2.0 (0.55-2.2)	44	TWO	RED
					12-28	0.85-1.95	48	TWO	BLUE
					3-15 (6-18)	0.2-1.0 (0.4-1.2)	45	ONE	WHITE
					6-30 (8-32)	0.4-2.0 (0.55-2.2)	46	TWO	WHITE
					11-28	0.75-1.95	48	TWO	BLUE
					3-15 (6-18)	0.2-1.0 (0.4-1.2)	47	ONE	BLUE
	Grey	5.00	125	175	6-30 (8-32)	0.4-2.0 (0.55-2.2)	48	TWO	BLUE
					3-15 (6-18)	0.2-1.0 (0.4-1.2)	57	ONE	ORANGE
					6-30 (8-32)	0.4-2.0 (0.55-2.2)	58	TWO	ORANGE
					11-21	0.75-1.45	13G	FOUR	WHITE
					14-32	1.1-2.2	14G	THREE	WHITE
					*20-40	1.4-2.8	59	THREE	ORANGE
Brown	1.50	38	57	3-15 (6-18)	0.2-1.0 (0.4-1.2)	13G	FOUR	WHITE	
				6-30 (8-32)	0.4-2.0 (0.55-2.2)	14G	THREE	WHITE	
				16-33	1.1-2.3	17	ONE	BLACK	
				*20-40	1.4-2.8	60	FIVE	WHITE	
				3-15 (6-18)	0.2-1.0 (0.4-1.2)	16	NONE	NONE	
				6-30 (8-32)	0.4-2.0 (0.55-2.2)	17	ONE	BLACK	
Brown	2.25	57	89	10-19	0.7-1.3	20G	TWO	RED	
				15-33	1.0-2.3	21G	THREE	BLUE	
				*20-40	1.4-2.8	61	THREE	BLACK	
				3-15 (6-18)	0.2-1.0 (0.4-1.2)	20G	TWO	RED	
				6-30 (8-32)	0.4-2.0 (0.55-2.2)	21G	THREE	BLUE	
				14-33	1.0-2.3	50	TWO	BLUE	
Brown	3.50	89	102	*20-40	1.4-2.8	62	FOUR	BLUE	
				3-15 (6-18)	0.2-1.0 (0.4-1.2)	24G	THREE	GREEN	
				6-30 (8-32)	0.4-2.0 (0.55-2.2)	25G	FOUR	GREEN	
				15-33	1.0-2.3	52	TWO	GREEN	
				*20-40	1.4-2.8	63	FIVE	GREEN	
				3-15 (6-18)	0.2-1.0 (0.4-1.2)	49	ONE	BLUE	
Red	5.00	125	175	6-30 (8-32)	0.4-2.0 (0.55-2.2)	50	TWO	BLUE	
				15-32	1.0-2.2	54	TWO	YELLOW	
				*20-40	1.4-2.8	64	THREE	BLUE	
				3-15 (6-18)	0.2-1.0 (0.4-1.2)	51	ONE	GREEN	
				6-30 (8-32)	0.4-2.0 (0.55-2.2)	52	TWO	GREEN	
				12-29	0.85-2.0	56	TWO	PURPLE	
Red	6.00	150	200	*20-40	1.4-2.8	65	THREE	GREEN	
				3-15 (6-18)	0.2-1.0 (0.4-1.2)	53	ONE	YELLOW	
				6-30 (8-32)	0.4-2.0 (0.55-2.2)	66	THREE	YELLOW	
				10-29	0.7-2.0	56	TWO	PURPLE	
				3-15 (6-18)	0.2-1.0 (0.4-1.2)	55	ONE	PURPLE	
				6-30 (8-32)	0.4-2.0 (0.55-2.2)	56	TWO	PURPLE	

**Note:** Figures in parenthesis denote alternative spring bench setting.  
Other spring ranges are available on request.

\*G 300 High Power (HP) actuator range.

# Dimensions

Table 7. G075 Actuators.

Travel		Spring Range psi	Spring No.	Bonnet MTG. DIA.A		H <sub>1</sub>		H <sub>2</sub>		H <sub>3</sub>	
ins.	mm			ins.	mm	ins.	mm	ins.	mm	ins.	mm
1.12	28	3 to 15	1	2.12	54	22.12	562	37.37	949	34	864
		6 to 30	2								
		11 to 22	32								
		14 to 33	33								
1.12	28	3 to 15	1	2.81	71	23.5	597	38.75	984	35.37	898
		6 to 30	2								
		11 to 22	32								
		14 to 33	33								
1.5	38	3 to 15	32	2.12	54	22.12	562	37.75	959	34	864
		6 to 30	33								
		14 to 30	42								
1.5	38	3 to 15	32	2.81	71	23.5	597	39.12	994	35.37	898
		6 to 30	33								
		14 to 30	42								
2.25	57	3 to 15	41			24.87	632	41.25	1048	36.75	1093
		6 to 30	42								

**Note:** Max. handwheel height with valve locked open.

Table 8. G150 Actuators.

Travel		Spring Range psi	Spring No.	Bonnet MTG. DIA.A		H <sub>1</sub>		H <sub>2</sub>		H <sub>3</sub>	
ins.	mm			ins.	mm	ins.	mm	ins.	mm	ins.	mm
1.12	28	3 to 15	4	2.12	54	27.5	699	44.12	1121	37.75	959
		6 to 30	5								
		11 to 21	7								
		14 to 33	8								
1.12	28	3 to 15	4	2.81	71	28.87	733	45.5	1156	39.12	994
		6 to 30	5								
		11 to 21	7								
1.5	38	3 to 15	7	2.12	54	27.5	699	44.5	1130	37.75	959
		6 to 30	8								
		12 to 21	10								
		15 to 33	11								
1.5	38	3 to 15	7	2.81	71	28.87	733	45.87	1165	39.12	994
		6 to 30	8								
		12 to 21	10								
2.25	57	15 to 33	11			30.62	778	48.37	1229	40.87	1038
		3 to 15	10								
		6 to 30	11								
2.25	57	15 to 31	44	32	813	49.75	1264	42.25	1073		
		3 to 15	10								
		6 to 30	11								
3.5	89	3 to 15	43	35.75	908	62.5	1588	53.75	1365		
		6 to 30	44								
		12 to 28	48								
4	102	3 to 15	45	38.75	984	65.5	1664	56.75	1441		
		6 to 30	46								
		11 to 28	48								
5	127	3 to 15	47	39.75	1010	68	1727	57.75	1467		
		6 to 30	48								

**Note:** Max. handwheel height with valve locked open.

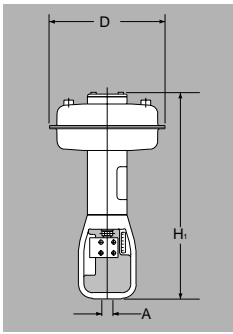

Table 9. G300 Actuators.

Travel		Spring Range psi	Spring No.	Bonnet MTG. DIA.A		H <sub>1</sub>		H <sub>3</sub>																			
ins	mm			ins.	mm	ins.	mm	ins.	mm																		
1.12	28	3 to 15	57	2.81	71	36.75	933	52.5	1335																		
		6 to 30	58																								
		11 to 21	13G																								
		14 to 32	14G																								
1.5	38	3 to 15	13G																								
		6 to 30	14G																								
		16 to 33	17																								
2.25	57	3 to 15	16																								
		6 to 30	17																								
		10 to 19	20G																								
		15 to 33	21G																								
2.25	57	3 to 15	16							3.56	91	38.12	968	53.93	1370												
		6 to 30	17																								
		10 to 19	20G																								
		15 to 33	21G																								
3.5	89	3 to 15	20G																								
		6 to 30	21G																								
		14 to 33	50																								
3.5	89	3 to 15	20G	5.75	146	42.12	1070	57.93	1471																		
		6 to 30	21G																								
		14 to 33	50																								
4	102	3 to 15	24G																								
		6 to 30	25G																								
		15 to 33	52																								
4	102	3 to 15	24G							5.75	146	42.12	1070	57.93	1471												
		6 to 30	25G																								
		15 to 33	52																								
5	127	3 to 15	49													3.56	91	41.87	1063	64.50	1638						
		6 to 30	50																								
		15 to 33	54																								
5	127	3 to 15	49	5.75	146	44.12	1121	66.75	1695																		
		6 to 30	50																								
		15 to 32	54																								
6	152	3 to 15	51																			3.56	91	47.37	1203	70	1778
		6 to 30	52																								
		12 to 29	56																								
6	152	3 to 15	51							5.75	146	49.62	1260	72.25	1835												
		6 to 30	52																								
		12 to 29	56																								
7	178	3 to 15	53													5.75	146	51.62	1311	80.25	2038						
		6 to 30	66																								
		10 to 29	56																								
8	203	3 to 15	55	5.75	146	54.87	1394	83.50	2121																		
		6 to 30	56																								

Table 10. G300 HP Actuators.

Travel		Spring Range psi	Spring No.	Bonnet MTG. DIA.A		H <sub>1</sub>		H <sub>3</sub>	
ins.	mm			ins.	mm	ins.	mm	ins.	mm
1.12	28	20 to 40	59	2.81	71	36.75	933	52.56	1335
1.5	38	20 to 40	60						
2.25	57	20 to 40	61						
2.25	57	20 to 40	61	3.56	91	38.12	968	53.93	1370
3.5	89	20 to 40	62						
3.5	89	20 to 40	62						
4	102	20 to 40	63	5.75	146	47.75	1213	63.62	1616
4	102	20 to 40	63						
4	102	20 to 40	63						
5	127	20 to 40	64	3.56	91	55.37	1406	78	1981
5	127	20 to 40	64						
5	127	20 to 40	64						
6	152	20 to 40	65	3.56	91	55.37	1406	78	1981
6	152	20 to 40	65						
6	152	20 to 40	65						
6	152	20 to 40	65	5.75	146	57.62	1463	80.25	2038
6	152	20 to 40	65						
6	152	20 to 40	65						



Standard Diaphragm Actuator Direct Acting.

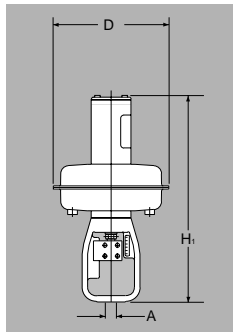

Standard Diaphragm Actuator Reverse Acting.

Diaphragm Actuator with Top mounted Handwheel Direct/Reverse Acting.

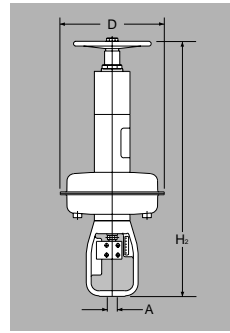

Diaphragm Actuator with Side mounted Handwheel Direct/Reverse Acting.

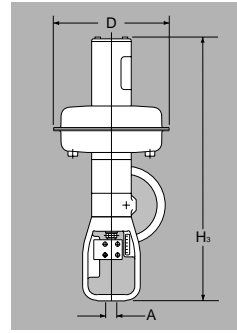

Table 11. 'G' Series Actuator Weights required without Handwheels.

Actuator size	Travel (ins.)	Bonnet MTG. Dia.A (ins)	WT. (KG).	WT. (LB).	Dia.D (ins./mm)
075	1 1/8	2 1/8	28	62	13 330
	1 1/2	2 13/16	29	64	
	2 1/4	2 13/16	32	70	
150	1 1/8	2 13/16	55	121	18 457
	1 1/4	2 13/16	56	123	
	2 1/4	3 9/16	62	136	
	3 1/2	3 9/16	70	154	
	4	3 9/16	70	154	
	5	3 9/16	72	158	
300	2 1/4	2 13/16	60	132	24 1/4 616
	1 1/8	2 13/16	140	308	
	1 1/2	2 13/16	142	312	
	2 1/4	3 9/16	144	317	
	3 1/2	3 9/16	161*	354	
	4	3 9/16	146	321	
	5	3 9/16	162	356	
	6	3 9/16	172	378	
	6	5 3/4	174	383	
	7	5 3/4	180	396	
8	5 3/4	180	396		

\*With limit stop and instrumentation fitted. 141 KG actuator only.

Table 12. 'G' Series Actuator Weights required with Handwheels.

Actuator size	Travel (ins)	Top Mounted		Side Mounted	
		KG	LB	KG	LB
075	1 1/8	40	88	38	84
150	2 1/4	20	44	82	181
300	3 1/2	---	---	216	476

# kentintrol™

The Company's policy is one of continuous improvement and the right is reserved to modify the specifications contained herein without notice.

Kent Introl Ltd  
 Armytage Road, Brighouse,  
 West Yorkshire, England. HD6 1QF  
 Telephone: +44 (0) 1484 710311  
 Fax: +44 (0) 1484 721253

email: info@kentintrol.com WWW: http://www.kentintrol.com